

MSP-Mojo

SavFIRE™ Target Board for MSP-eZ430U

Description

The MSP-Mojo is a target board for Texas Instruments MSP-eZ430U development system. It includes the QF1D512 SavFIRE™ and the MSP430F2013 processor. This board allows you to implement high performance digital filtering with your MSP430 processor in a matter of minutes using the Quickfilter Pro QF1D512 development software and MSP430 specific software drivers.

Features

Digital Filter Characteristics

- Maximum 512-tap symmetric or 256-tap non-symmetric digital FIR filter
- 12 - 24 bit data words, up to 32 bit coefficients
- Programmable Box-car Averaging and Down-sampler including bypass mode
- Reprogrammable in circuit
- Up to 500ksp/s

Board

- Miniature audio jack for analog input
- MSP430F2013 processor
- Four pin interconnect to the MSP-eZ430U board
- Expansion header for standalone use

Expansion Header

- Interface header pads allow access to major signal lines
- Included header pins can be soldered to either top or bottom side of board as required

Software

- Complete C source code to control the SavFIRE™ on an MSP-430 is available on the Quickfilter website

Design Software & Filter Types

- Create a complete filter design using Quickfilter Pro Design Software
- Supports many filter types including Lowpass, Notched Lowpass, Highpass, Bandpass, Dual Bandpass, Bandstop, and Dual Bandstop
- Parks-McClellan & Windows Sinc filter algorithms

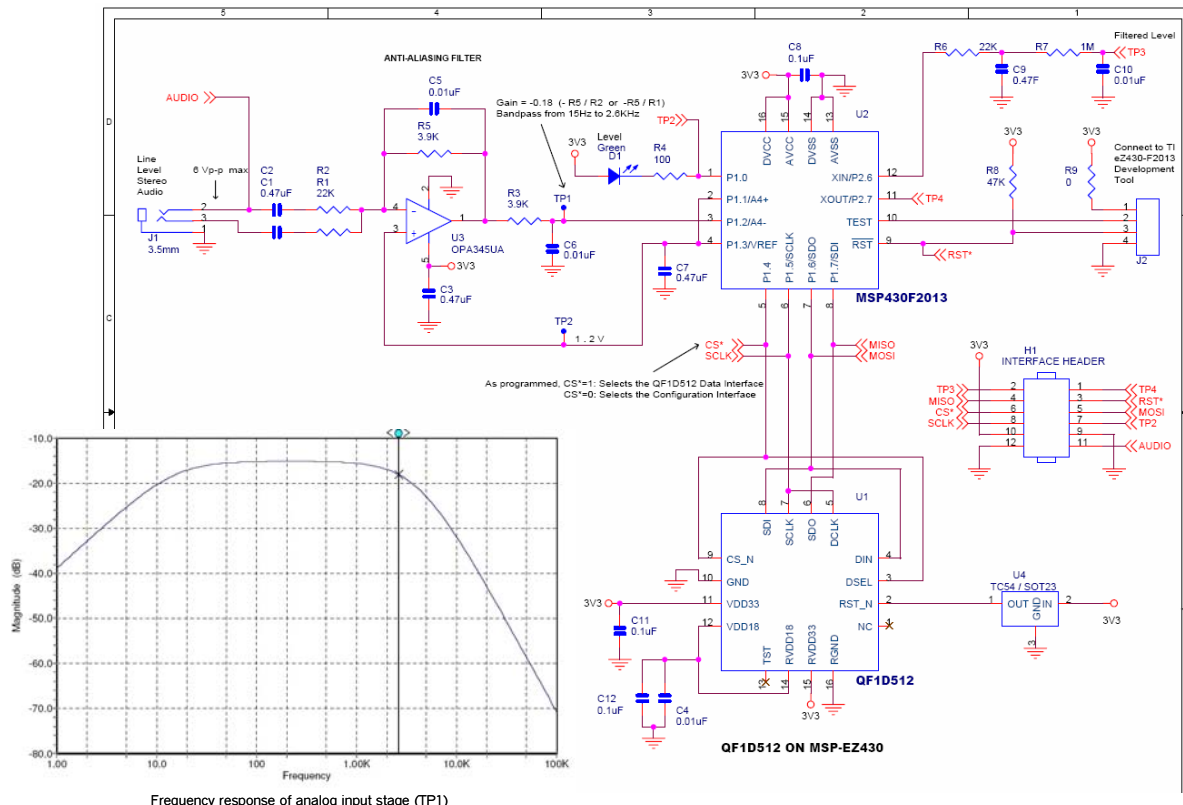
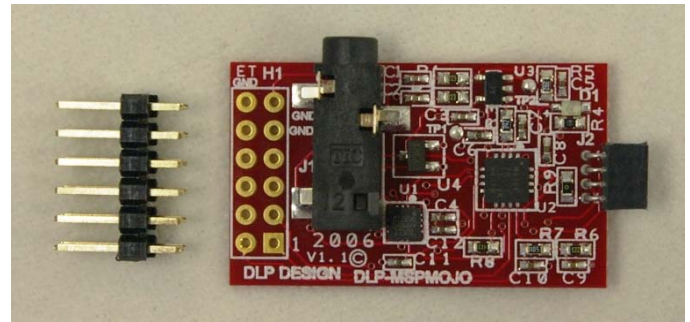

Board Schematic



Original TI MSP-eZ430U board

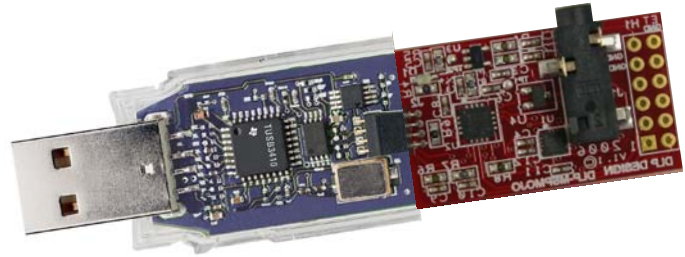

TI MSP-eZ430U board with MSP-Mojo

Filter Design Software

The Quickfilter Pro software allows you to design your filter in a matter of minutes. A variety of different filter types can be designed low-pass, notched low-pass, high-pass, band-pass, dual band-pass, band-stop, and dual band-stop. Currently available filter algorithms include Parks-McLellan and Windows Sinc. Desired frequencies, slope and attenuation can be input and the theoretical results observed. Chip configurations for averaging, decimation, and input data format are configured using the software. Completed designs are then saved as a data file for your MSP430 software.

For more information please visit the Quickfilter website at the following link: <http://www.quickfiltertech.com/files/MSP-Mojo2>

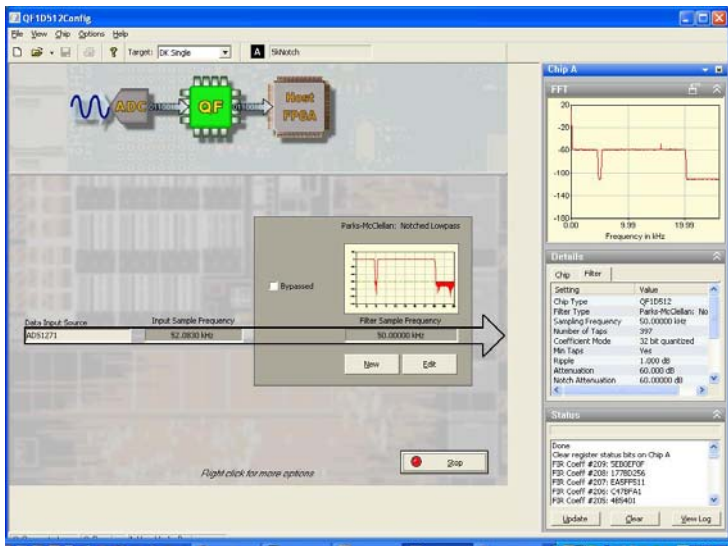

Chip Design Screen

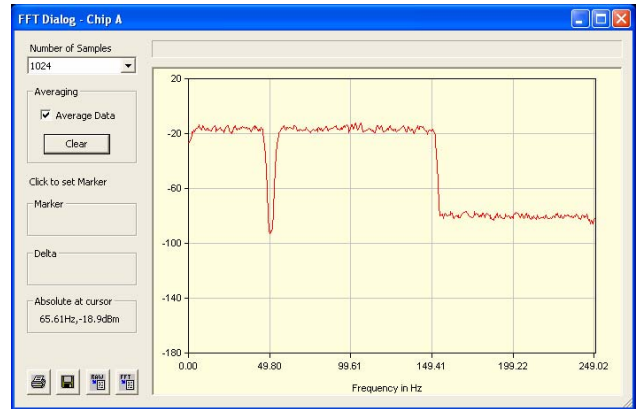

Actual Filter Output from QF1D512

Steps to implement your filter:

1. Configure your filter for the QF1D512 using the Quickfilter Pro software
2. Save your design and export in HEX format
3. Convert the filter configuration to C source / header files using the provided SavFIRHex2C utility
4. Compile the filter source code with your program code for the MSP430
5. Download to the MSP430F2013 processor using the IAR Embedded Workbench™*

* Embedded Workbench is a trademark of IAR

Contact Information: Quickfilter Technologies, Inc.
 1024 South Greenville Avenue, Suite 100
 Allen, TX 75002 Phone: 214-547-0460

Web: www.quickfiltertech.com
Email: sales@quickfilter.net

Ordering Information: QF1D512-eZ430 MSP-Mojo board+expansion header
 Mouser P/N: DLP-MSP-MOJO