

1) Introduction

The QF1D512-Dipster provides a means of prototyping the QF1D512 using a 14-pin Dual Inline Package (DIP) format.

The board has four components, the QF1D512, two power decoupling capacitors, C1 and C2, and the DIP pins.

There are 5 cut points that may be cut and/or resoldered as needed. CP1, 2 and 3 connect the lines that are typically used to implement Coprocessor mode. CP4 and CP5 connect the onboard 1.8V regulator to the chip's power pins. Every effort has been made to keep traces away from the cut line of all cut points.

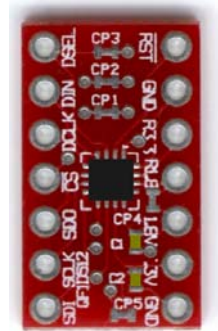

2) Dimensions

Width	10.5mm
Length	18mm
Height (mounted on PCB)	5mm
Pin length height	8mm

3) Schematic

Figure 1 – QF1D512-Dipster Schematic

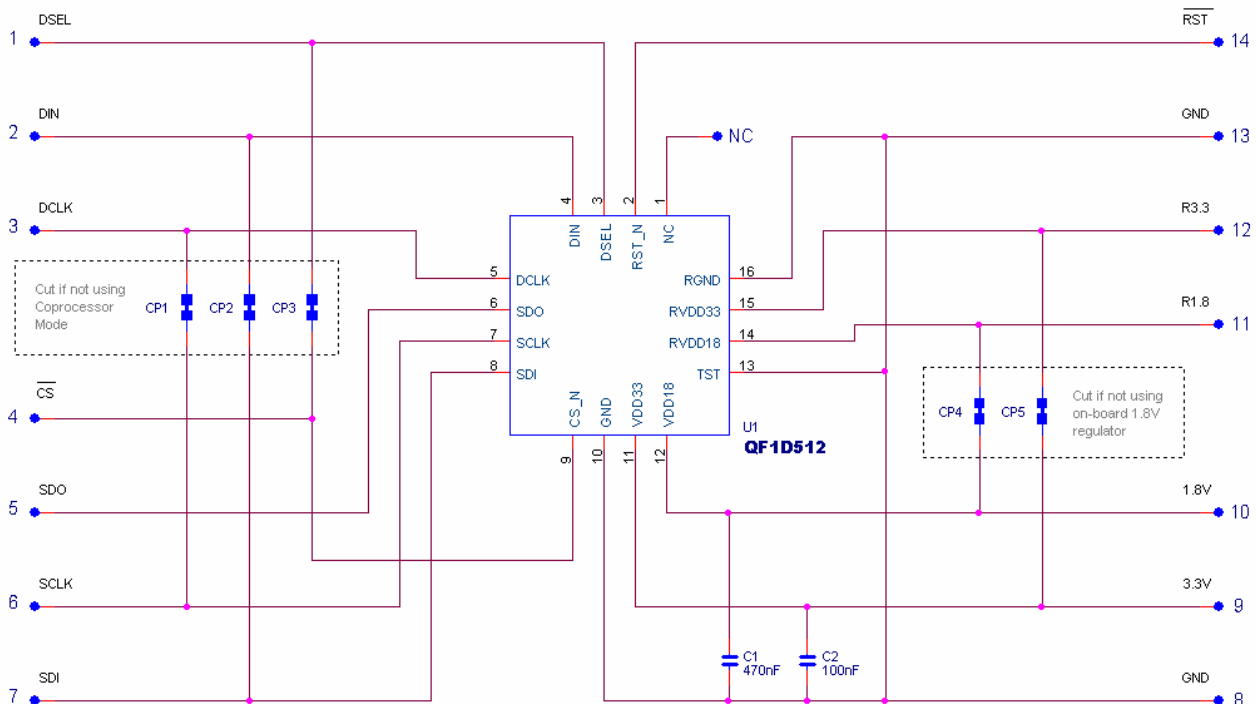



Product Brief

Contact Information:

Quickfilter Technologies, Inc.
1024 S. Greenville Avenue, Suite 100
Allen, TX 75002-3324

General: info@quickfilter.net
Applications: apps@quickfilter.net
Sales: sales@quickfilter.net
Phone: 214-547-0460
Fax: 214-547-0481
Web: www.quickfiltertech.com

The contents of this document are provided in connection with Quickfilter Technologies, Inc. products. Quickfilter makes no representations or warranties with respect to the accuracy or completeness of the contents of this publication and reserves the right to make changes to specifications and product descriptions at any time without notice. No license, whether express, implied, arising by estoppel or otherwise, to any intellectual property rights is granted by this publication. Except as set forth in Quickfilter's Standard Terms and Conditions of Sale, Quickfilter assumes no liability whatsoever, and disclaims any express or implied warranty, relating to its products including, but not limited to, the implied warranty of merchantability, fitness for a particular purpose, or infringement of any intellectual property right.

Quickfilter's products are not designed, intended, authorized or warranted for use as components in systems intended for surgical implant into the body, or in other applications intended to support or sustain life, or in any other application in which the failure of Quickfilter's product could create a situation where personal injury, death, or severe property or environmental damage may occur. Quickfilter reserves the right to discontinue or make changes to its products at any time without notice.

© 2007 Quickfilter Technologies, Inc.
All rights reserved.

Quickfilter, the Quickfilter logo and combinations thereof, are trademarks of Quickfilter Technologies, Inc.

Other product names used in this publication are for identification purposes only and may be trademarks of their respective companies.